

# Brass Wingback Elbow (BSP Thread)

**Durable Speedfit to FSBP 90° elbow with integrated back plate (ideal for Bib taps)**

## Overview

John Guest brass wingback elbow push-fit fitting connects metric to imperial pipe. The integral wall plate ensures the fitting can be easily mounted. Fast and simple to install, John Guest Air and Pneumatics creates an instant connection and airtight seal without the need for tools, hot works or sealing agents. Air piping systems can be set up and installed 50% quicker than traditional methods.

The unique collet locking design firmly and securely holds the pipe in place without deforming the pipe or restricting flow. Fittings are also fully demountable, reducing system downtime during maintenance and making it quick and easy to modify or extend systems.

Designed in brass, fittings are compatible with John Guest nylon, powder coated aluminium or LLDPE tubing, as well as copper, PEXa and other soft metal pipe materials. All John Guest fittings are manufactured and assembled in the UK.



## Features & Benefits

- Brass wall mounted elbow with push-fit to FBSP connections
- Airtight connection with superior flow characteristics
- Instant push-fit connection and demountable without tools
- Secure collet cover prevents accidental disconnection
- Suitable for air and pneumatics piping systems up to 10 bar
- Ideal for air, inert gases and vacuum applications
- Food grade fitting suitable for potable liquids
- Compatible with soft metal or plastic pipe/tubing

Product code	Description	Size	Bag QTY
PM15WB	Brass Wing Back Elbow	15mm x 1/2" BSP	1
PM22WB	Brass Wing Back Elbow	22mm 3/4" BSP	1



# Brass Wingback Elbow (BSP Thread)

## Working parameters & specifications

Application	Maximum working pressure, bar
Air	16 Bar

Materials	
Body	Brass
O-Ring	Nitrile, Black
Collet	Acetal Copolymer (Unfilled), Black
Collet Teeth	Stainless Steel 301

## Dimensions – All measurements in mm unless otherwise stated

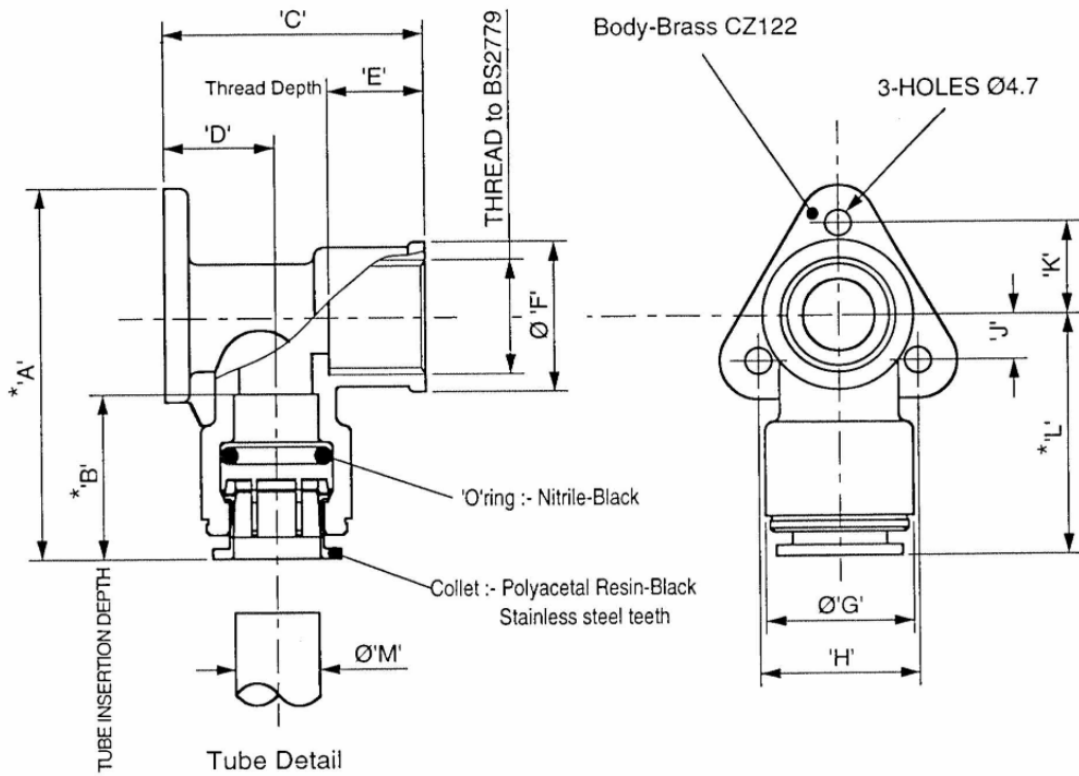

\* These dims with collet in fully released position.

Dimension Chart

Product No.	Dim.'A'	Dim.'B'	Dim.'C'	Dim.'D'	Dim.'E'	$\varnothing'$ 'F'	$\varnothing'$ 'G'	Dim.'H'	Dim.'J'	Dim.'K'	Dim.'L'	$\varnothing'$ 'M'	Thread
PM15WB	66.4	28.0	47.0	20.0	15.0 Min	27.3	26.8	29.4	8.5	17.0	42.4	15.0±0.1	1/2 BSP
PM22WB	79.0	23.3	52.0	24.5	15.0 Min	33.5	34.5	42.0	11.0	22.0	50.0	22.0±0.1	1/2 BSP